

# CABIN AIR FILTER – INSTALLATION INSTRUCTIONS

Part No.: PC5863X Est. Installation Time: less than 15 mins

Subaru OE: 72880-AJ010; Toyota OE: SU003-02112; Honda OE: 80291-SAA-J01

The Cabin air filter is located behind the glove compartment

- Open the glove box. Slide off the damper (Fig 1)
- Push in each side of the glove box and pull the glove box towards you to disconnect the claws (Fig 2)
- Pull out the glove box and disconnect the lower claws
- Remove the filter cover (Fig 3)
- Remove the old filter from assembly, taking note the air flow arrow indicator on the side of the old filter (Fig 4)
- Insert new filter into the assembly, making sure the air flow direction is correct according to the arrow indicator
- Replace the rest of the glove box assembly by reversing the removal procedure

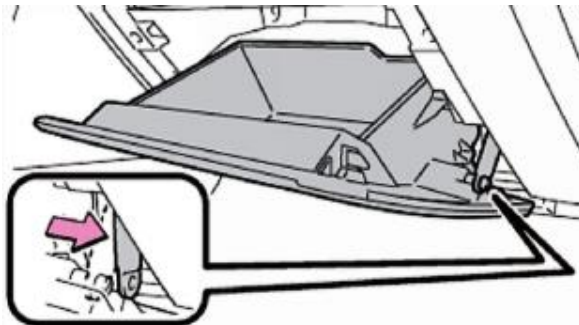

Fig 1

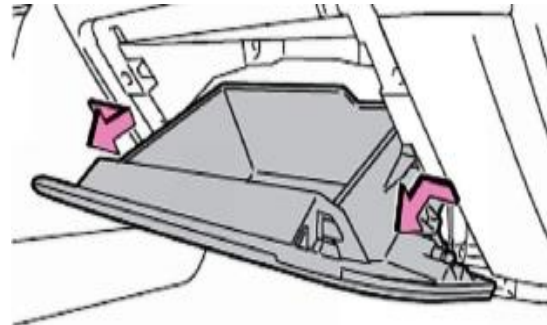

Fig 2

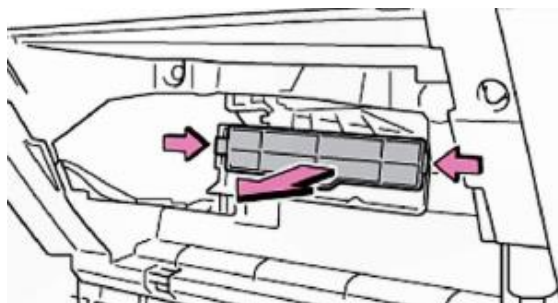

Fig 3

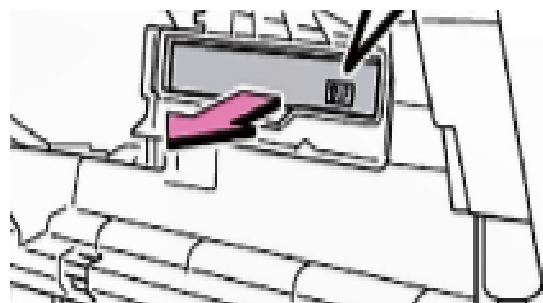

Fig 4

This is only a guide and may not be for exact model. See Owner's manual and/or local mechanic for exact instructions for the particular model.