

CABIN AIR FILTER – INSTALLATION INSTRUCTIONS

Est. Installation Time: less than 15 min.

The Cabin Air Filter is located behind the glove box.

1. Remove the glove box

Remove panels gain access to the screw locations for the glove box.

1. Dashboard lower panel.
 2. Remove passenger side fuse panel.
 3. Remove the panel under dashboard (remove 6 screws)
2. Remove the 4 screws holding the bottom of the glove box.

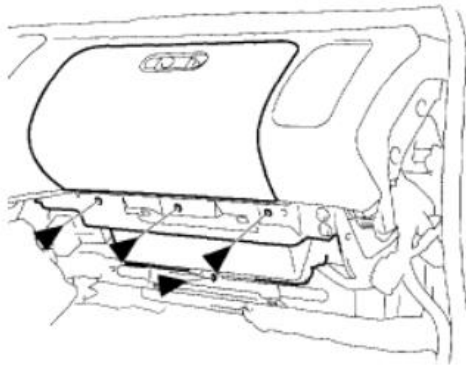

3. Insert a flat head screwdriver in the notch (A) of the cap (B), and release the hooks by prying up the cap.

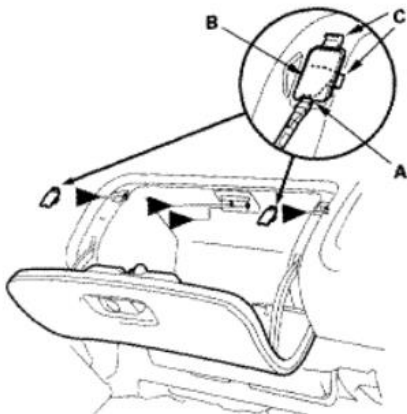

4. Remove the 4 screws under the caps
5. Remove the glove box

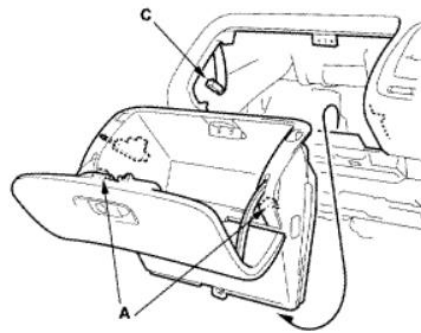

This is only a guide and may not be for exact model. See Owner's manual and/or local Technician for exact instructions for the particular model.

CABIN AIR FILTER – INSTALLATION INSTRUCTIONS

Est. Installation Time: less than 15 min.

6. Remove the 2 screws in the glove box frame to remove the frame.

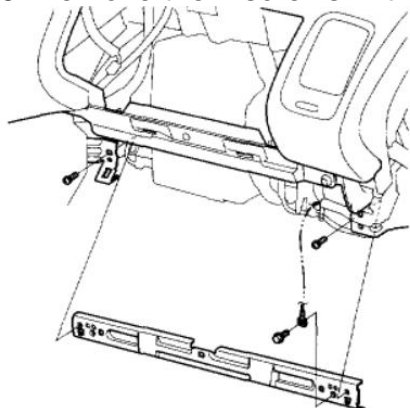

7. Remove the filter lid (A)

8. Remove the upper & lower filter assembly taking note of the air flow Indicator arrows.

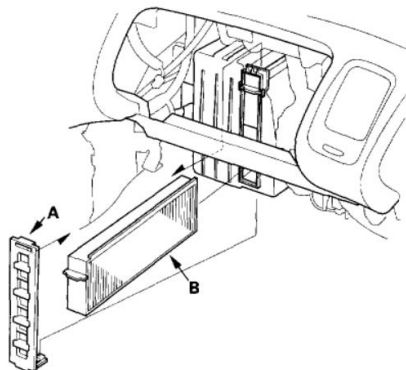

9. Remove filter from the filter housing Place new filter into housing following the correct air flow direction. (B)

10. Complete the install by reversing the removal procedure.

This is only a guide and may not be for exact model. See Owner's manual and/or local Technician for exact instructions for the particular model.